



AMERICAN SPECIALTIES, INC.

441 Saw Mill River Road, Yonkers, NY 10701 (914) 476-9000

MODEL No: 0400-D

ISSUED: 1-87

REVISED: 7-99

HEAVY DUTY STAINLESS STEEL SOAP DISH

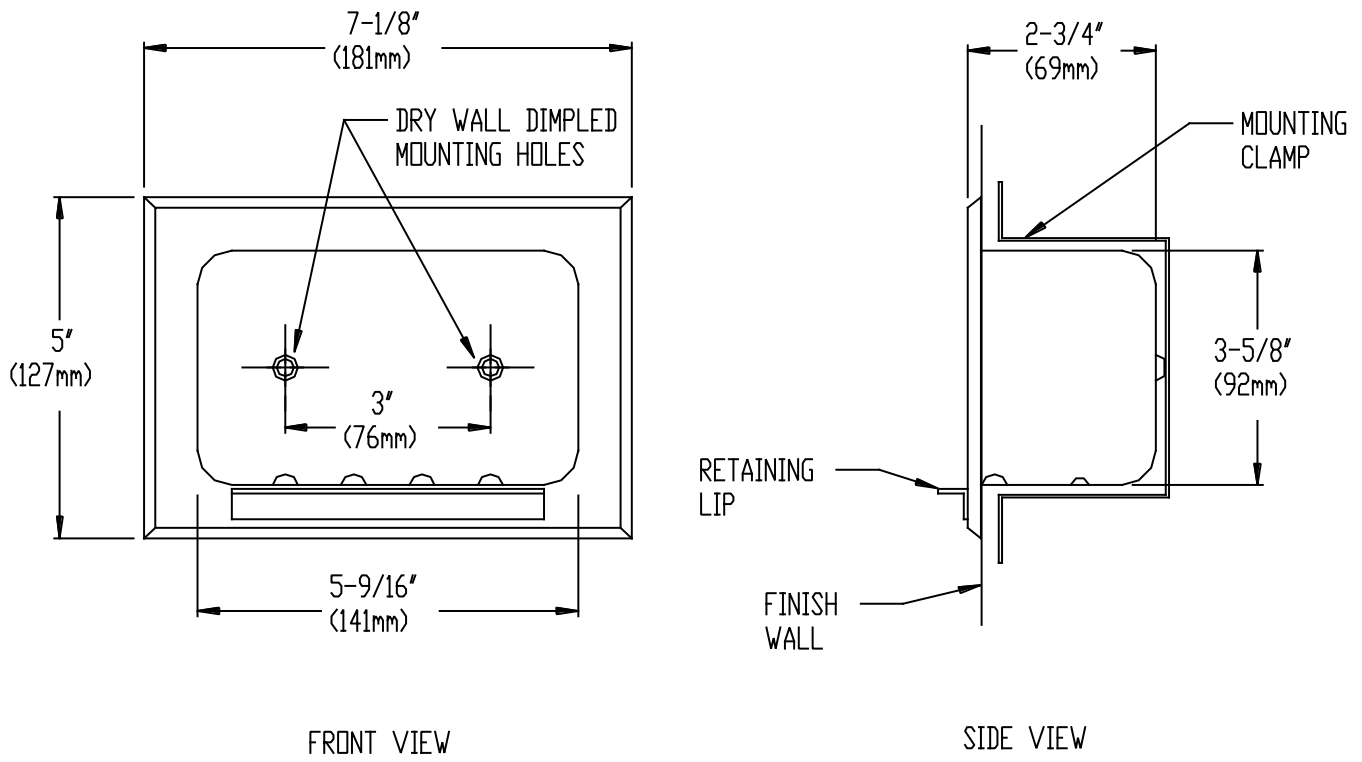

FRONT VIEW

SIDE VIEW

SPECIFICATION

Heavy Duty Stainless Steel Soap Dish for dry wall mounting shall be fabricated of alloy 18-8 seamless deep drawn stainless steel, type 304 №20 gauge with sandblasted interior. Exterior shall have polished bright finish. Retaining lip shall be welded to body and shall project 5/8" (16mm) with rounded corners. Mounting clamp shall be fabricated of №18 gauge corrosion protected steel with mounting holes drilled and tapped for 8-32 machine screws. Patterned raised dimples on soap shelf shall provide water runoff path and prevent soap from slipping

Heavy Duty Stainless Steel Soap Dish shall be Model №0400-D of American Specialties, Inc., 441 Saw Mill River Road, Yonkers, New York 10701-4913.

INSTALLATION

For compliance with ADA Accessibility Guidelines, install unit so that soap shelf is 54" (1372mm) maximum above finished floor (AFF) if clear floor side reach is provided or 48" (1219mm) maximum AFF if clear forward reach access is provided or if unit is installed in shower stall or 46" (1168mm) maximum AFF if side reach over obstruction is only provided (i.e. vanity), or 36" (915mm) maximum in bathtubs. Loosely attach mounting clamp to back of unit with two (2) 8-32 machine screws (supplied). Insert unit into wall opening and adjust clamp so that it grips surface inside opening. Secure unit by tightening screws.

Rough wall opening (RWO) required is 6-1/8"W x 4-1/8"H x 4"D (156mm x 105mm x 102mm)

OPERATION

Raised dimples on the soap shelf allow water to drain away and provide gripping surface to retain soap.

Accessory Specialties

AMERICAN DISPENSER

Desert Ray Products

WATROUS INC.