

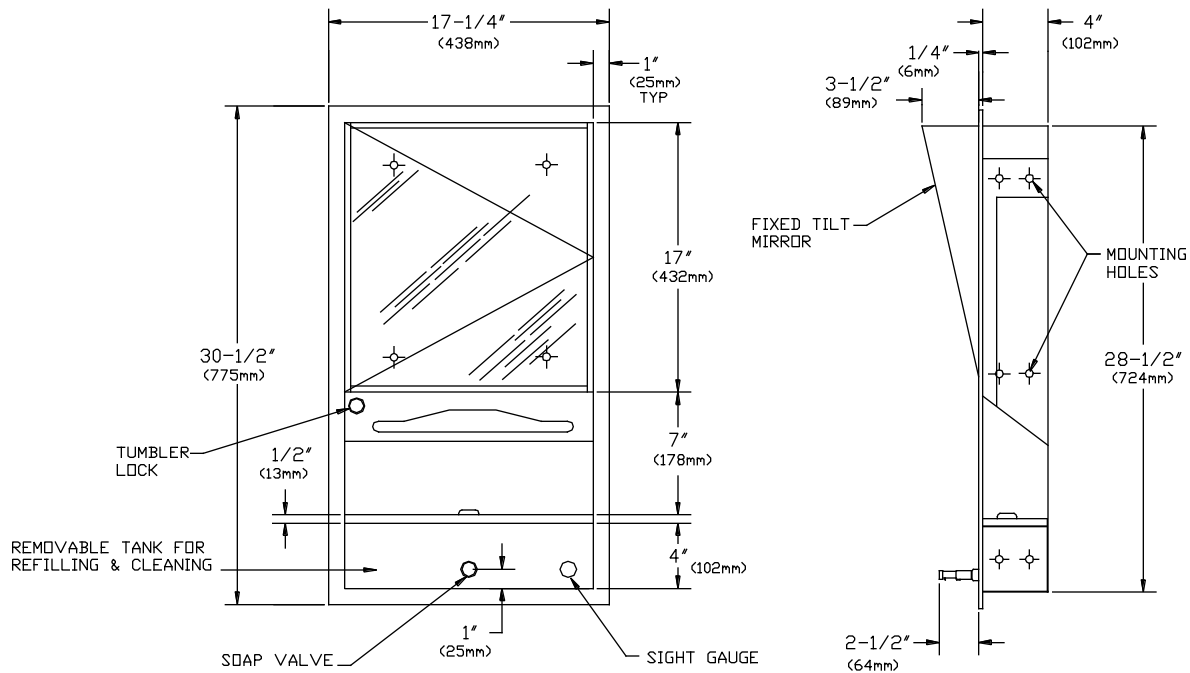

AMERICAN SPECIALTIES, INC.
441 Saw Mill River Road, Yonkers, NY 10701 (914) 476-9000

MODEL No:	0430-05
ISSUED:	1-87
REVISED:	9-96

RECESSED CABINET WITH SHELF, FIXED TILT MIRROR, PAPER TOWEL AND SOAP DISPENSER



SPECIFICATION

Recessed Cabinet with Shelf, Fixed Tilt Mirror, Paper Towel and Soap Dispenser shall hold 800 standard multi-fold or 600 standard C-fold paper towels and dispense 101 ounces (3liters) of liquid soap, lotion or detergent by way of a multi-purpose push valve. Cabinet, door, dispenser tank and frame shall be fabricated of alloy 18-8 stainless steel, type 304, N^o 22 gauge. Towel dispensing slot shall have a fully hemmed-in rolled edge for snag-free dispensing and user safety. Door shall be attached to cabinet at side with a full length 3/16" Dia. (4.8mm) stainless steel multi-staked piano hinge. Soap dispenser and door shall be held closed with a tumbler lock keyed alike to other ASI Washroom Equipment. Fixed Tilt Mirror shall be fabricated of 1/4" thick plate glass, warranted for 15 years. Face trim shall be 1" (25.4mm) wide formed from one piece with no mitres, welding or open seams and have 1/4" (6.35mm) square return to wall. Structural assembly of all components shall be of welded construction. A tamper resistant sight gauge shall be provided. Valve operation shall comply with ADA Accessibility Guidelines by requiring no more than 5 lbs_f (22.2 Newtons) pressure to actuate and require no grasping or twisting by operator. Valve shall be constructed of a chrome-plated brass body with stainless steel and plastic internal parts. All exposed metal surfaces shall be N^o4 satin finish and be protected during shipment with a PVC film easily removable after installation.

Recessed Cabinet with Shelf, Fixed Tilt Mirror, Paper Towel and Soap Dispenser shall be Model N^o 0430-05 as fabricated by American Specialties, Inc. 441 Saw Mill River Road Yonkers, New York 10701-4913

INSTALLATION

Unit is recessed mounted in wall using N^o 10 self tapping screws (supplied) through concealed mounting holes provided.

Rough wall opening (RWO) required is 15-3/4" W x 29" H x 4-1/4" D minimum (400mm x 736mm x 108mm).

For compliance with ADA Accessibility Guidelines, unit should be installed so bottom edge of the reflecting surface is no higher than 40" (1015 mm) above the finished floor. Note that top of RWO is 3/4" (19mm) below top of unit.

OPERATION

Soap is manually dispensed by pushing valve button until supply is depleted. Towels are self-feeding until supply is depleted. Unit may be reloaded easily by opening door or tank assembly with a partial load in-place and will continue to feed properly. Tank supply is replenished manually on cycle determined by maintenance needs.

Accessory Specialties

AMERICAN DISPENSER

Desert Ray Products

WATROUS INC.