



AMERICAN SPECIALTIES, INC.

441 Saw Mill River Road, Yonkers, NY 10701 (914) 476-9000

MODEL No: 046921

ISSUED: 1-87

REVISED: 3-99

RECESSED ROLL PAPER TOWEL DISPENSER AND WASTE RECEPACLE

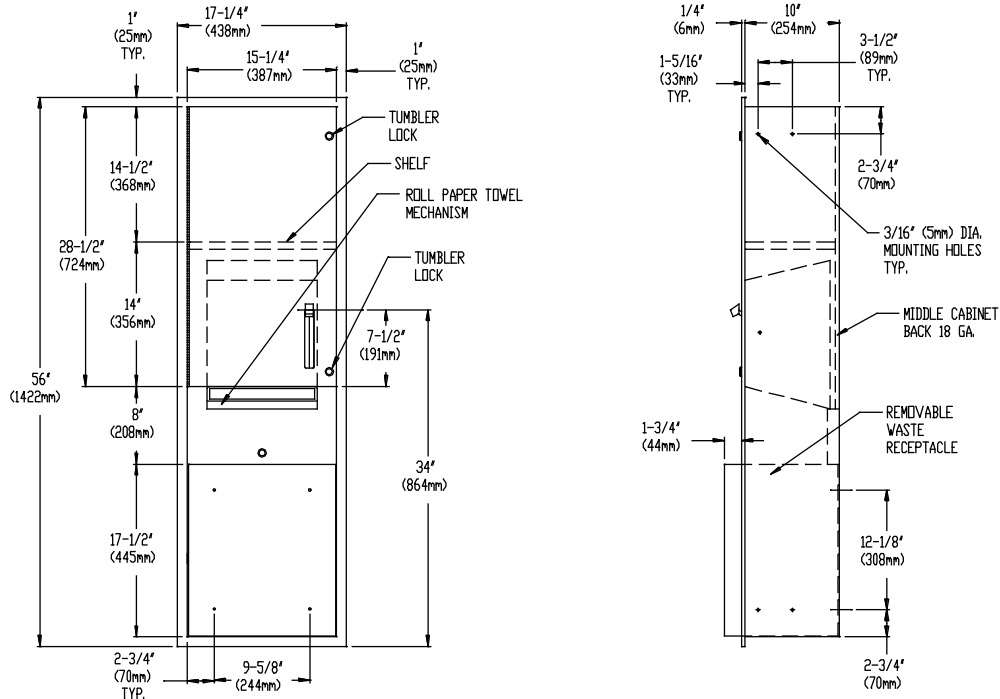

SPECIFICATION

Recessed Roll Paper Towel Dispenser and Waste Receptacle shall hold and dispense one 8" or 9" wide standard towel rollup to 800 ft. (244m) long and one stub roll up to 4" (102mm) diameter and shall have a waste capacity of 15 gal (56.8 liters). Unit frame, waste container and cabinet shall be fabricated of alloy 18-8 stainless steel, type 304, N^o 22 gauge; towel dispenser door shall be same grade N^o 18 gauge; unit back plate for mechanism shall be fabricated of N^o 18 gauge; all exposed surfaces shall have N^o 4 satin finish protected by a plastic PVC film easily removed after installation. Towel dispensing slot shall be smooth and burr-free for snag-free dispensing and user safety. Door shall be attached to cabinet at side with a full length 3/16" dia. stainless steel multi-staked piano hinge and be held closed with a tumbler lock keyed alike to other ASI Washroom Equipment. Waste container shall have hemmed edges for safety and shall be retained by a tumbler lock keyed alike to other ASI Washroom Equipment. Face trim shall be 1" (25mm) wide formed from one piece with no mitres, welding or open seams and have 1/4" (6mm) square return to wall. Structural assembly of all components shall be of welded construction.

Recessed Roll Paper Towel Dispenser and Waste Receptacle shall be Model N^o 046921 as fabricated by American Specialties, Inc., 441 Saw Mill River Road, Yonkers, New York 10701-4913

INSTALLATION

Unit is mounted in wall recess using N^o10 self tapping screws (supplied) through concealed mounting holes provided. For compliance with ADA Accessibility Guidelines, unit should be installed so that towel dispenser lever is 54" (1372mm) maximum above finished floor (AFF) if clear floor side reach access is provided or 48" (1219mm) maximum AFF if clear floor forward reach access only is provided. Note that top of RWO is 3/4" (19mm) below top of unit.

Rough Wall Opening (RWO) required is..... 15-3/4"W x 54-1/2"H x 10-1/4"D (400mm x 1384mm x 260mm).

OPERATION

Towels are fed by lever action until supply is depleted. Towel feed length is adjustable for economy by pin (supplied) limiting of lever stroke length. Unit may be reloaded with a full roll to automatically start when finished with an existing partial roll. Waste container is emptied manually on cycle determined by maintenance needs.

Accessory Specialties

AMERICAN DISPENSER

Desert Ray Products

WATROUS INC.