



AMERICAN SPECIALTIES, INC.

441 Saw Mill River Road, Yonkers, NY 10701 (914) 476-9000

MODEL No: 04813-HC

ISSUED: 1-87

REVISED: 4-99

PARTITION MOUNTED TOILET PAPER DISPENSER WITH SANITARY DISPOSAL

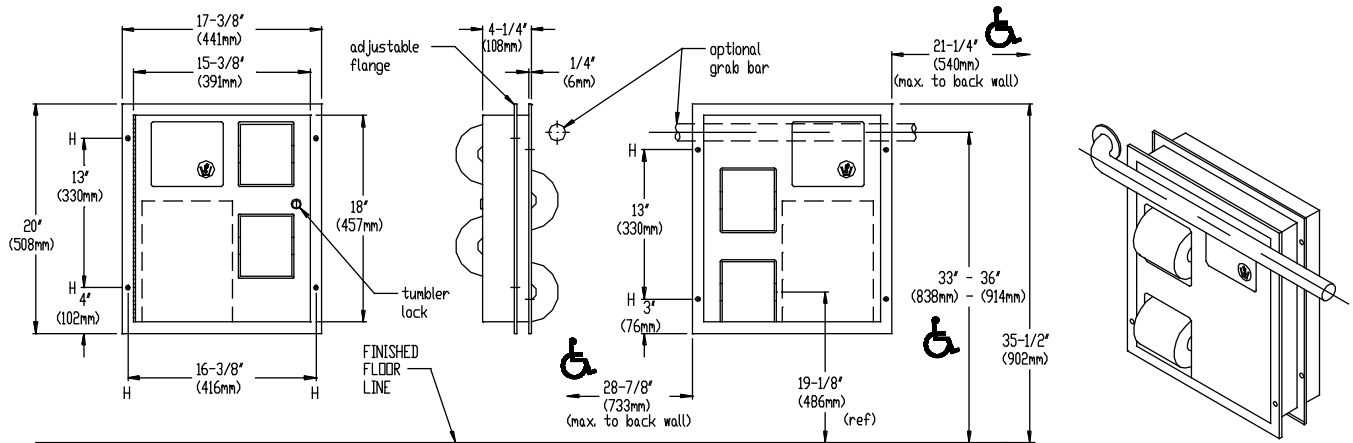

SPECIFICATION

Partition Mounted Dual Access Toilet Paper Dispenser and Sanitary Disposal shall hold and dispense four rolls standard or 1800 sheet 4-1/2" x 5-1/4" (114mm x 133mm) toilet paper. Napkin disposal capacity shall be 1.2 gal. (4.5 liters). Dispenser door shall be fabricated of alloy 18-8 stainless steel, type 304, 18 gauge; face frame and cabinet shall be 22 gauge; all exposed surfaces shall have N^o4 satin finish and be protected by a plastic PVC film easily removed after installation. Disposal door shall be hung on spring tensioned hinges and shall have international graphic symbol. Dispenser/waste door shall be attached to cabinet at side with a full length 3/16" (5mm) dia. stainless steel multi-staked piano hinge and shall be held closed with a tumbler lock keyed alike to other ASI Washroom Equipment. Face trims shall be 1" (25mm) wide formed from one piece with no mitres, welding or open seams and have 1/4" (6mm) square return to face of partition. Structural assembly of all components shall be of welded construction. Cabinet shall include four theft resistant spindles.

Partition Mounted Toilet Paper Dispenser with Sanitary Disposal (for use with optional grab bar) shall be Model N^o 04813-HC as fabricated by American Specialties, Inc., 441 Saw Mill River Road, Yonkers, New York 10701-4913

INSTALLATION

Unit is mounted in partition using N^o 10 self tapping screws (supplied). Unit should be installed so that top of trim is 35-1/2" (902mm) above finished floor. Note partition cutout is 7/8" (22mm) below top of face trim.

Partition Cutout Required is... 15-1/2" W x 18-1/4"H x 1/2" to 3-3/4" thick partition (394mm x 733mm x 13mm x 95mm)

OPERATION

Toilet paper rolls feed freely until depleted, level of supply is constantly visible for low level warning. Waste container is emptied manually on cycle determined by maintenance needs. Toilet paper rolls and waste receptacle are serviced from one side, for both stalls, by unlocking and opening door.

Accessory Specialties

AMERICAN DISPENSER

Desert Ray Products

WATROUS INC.