



AMERICAN SPECIALTIES, INC.

441 Saw Mill River Road, Yonkers, NY 10701 (914) 476-9000

MODEL No: 0625

ISSUED: 1-87

REVISED: 4-99

CHANNEL FRAME MIRROR WITH SHELF

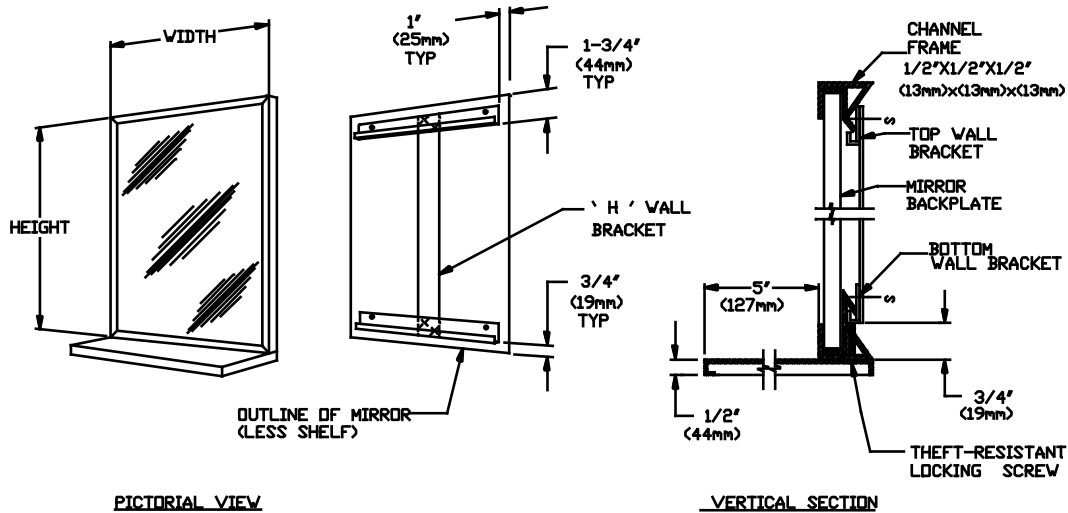

SPECIFICATION

Channel Frame Mirror with Shelf shall have frame fabricated of alloy 18-8 stainless steel, type 304 with mitred corners, N^o20 gauge. Shelf shall be N^o18 gauge, same grade. Mirror glazing shall be _____ (insert glazing option) and shall be warranted for 15 years against silver spoilage. All edges of mirror shall be protected by friction and chafe absorbing fillers. Back of mirror shall be protected by full size shock-absorbing water-resistant filler and full size one piece N^o20 gauge corrosion protected steel. Top and bottom wall mounting brackets shall be spot welded into an "H" and supplied with all required mounting hardware. Mirror shall be secured to lower bracket with a locking screw. Finish of unit shall be protected from marring by easily removed self adhesive polyvinyl (PVC) film.

Channel Frame Mirror with Shelf shall be Model N^o 0625-___ (insert glazing option) as fabricated by American Specialties, Inc., 441 Saw Mill River Road, Yonkers, New York 10701-4913

MATERIALS

- Frame:** Alloy 18-8, type 304, N^o20 gauge (.036 in. [.91mm] thick) stainless steel. Unitized all roll-formed one piece construction. Exposed surfaces have satin finish. Edges and corners are burr free.
- Shelf:** Alloy 18-8, type 304, N^o18 gauge (.048 in. [1.2mm] thick) stainless steel. Unitized all welded construction. Exposed surfaces have satin finish. Edges and corners are burr free.
- Glass:** Standard -A glazing is N^o1 quality, 1/4" (6mm) thick plate/float, silver coated and hermetically sealed with a uniform copper plating, and warranted against silver spoilage for 15 years. Mirrors meet Federal Spec. DD-M-411C, ASTM -C-1036-91.
- Filler:** Expanded polyethylene microcell foam sheet material, abrasion resistant and shock absorbing, water resistant, 1/8" (3.2m) total layer thickness.

FABRICATION NOTE FOR SPECIFICATION

Mirrors larger than 21 sq. ft. (1.95m²) are fabricated in two or more sections to provide installation and handling ease.

INSTALLATION

Install "H" wall brackets level and plumb per diagram location using **ONLY** N^o10 Pan Head screws supplied. Hang mirror on brackets and tighten locking screw at bottom (note: this screw should be started prior to hanging frame). For compliance with ADA Accessibility Guidelines, bottom edge of reflecting surface should be no higher than 40" (1016mm) above finished floor (AFF).

GLAZING OPTIONS

Units are supplied with 1/4" thick plate glass mirrors as designated by the -A suffix standard. Other glazing options are available. For a complete description of -A or any other available glazing, see the **MIRROR GLAZING OPTIONS** chart.

Accessory Specialties

AMERICAN DISPENSER

Desert Ray Products

WATROUS INC.