



**AMERICAN SPECIALTIES, INC.**  
441 Saw Mill River Road, Yonkers, NY 10701 (914) 476-9000

MODEL No: 0705-Z

ISSUED: 1-87

REVISED: 9-96

**TOILET PAPER HOLDER**

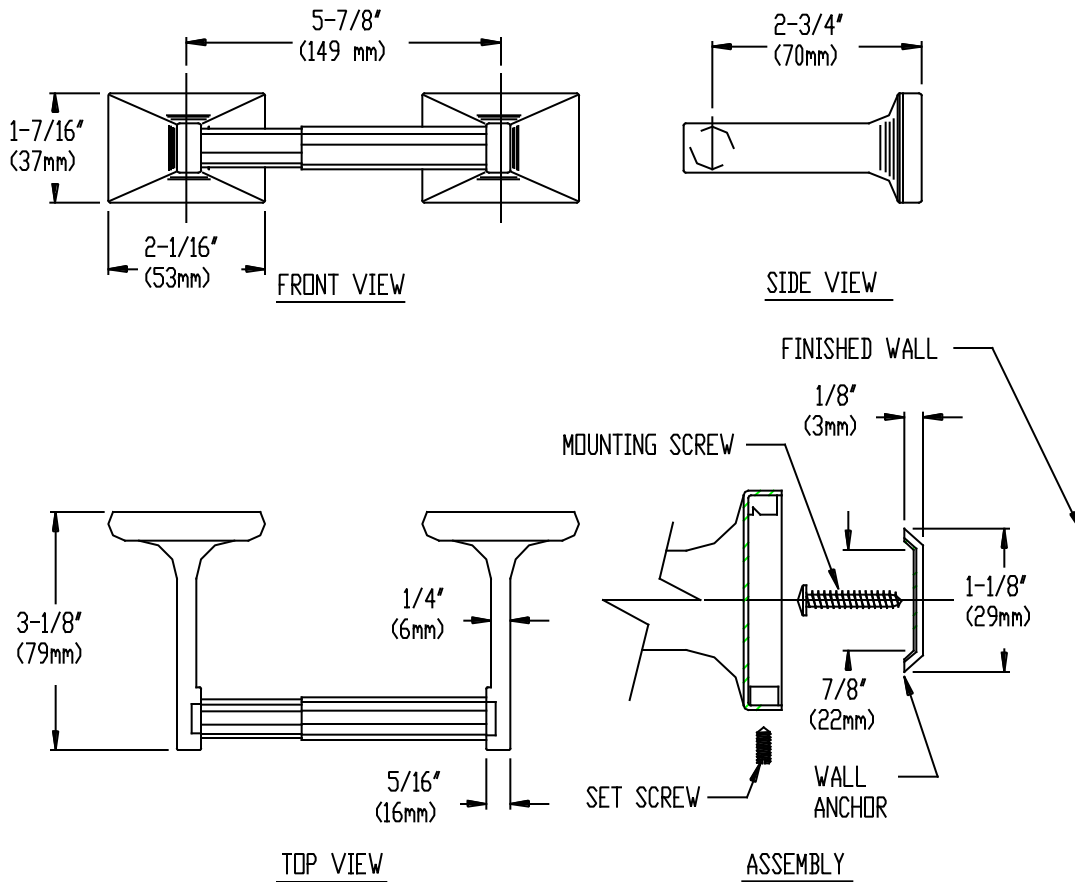

**SPECIFICATION**

Toilet Paper Roll Holder shall be fabricated of triple chrome plated rust proof Zamak. Roller shall hold and dispense all standard core roll tissue up to 5" (127mm) dia. One stainless steel hex socket set screw shall be provided along perimeter of each roll holder post flange for anchoring to stainless steel adjustable wall bracket. Roll holder posts shall be theft resistant when tempered hardened stainless steel set screws are installed and tightened into brackets. Mounting hardware shall be provided. Roller shall be plastic with internal spring for tension and shall be removable from brackets for easy loading. Unit shall meet appropriate FHA and other federal specifications.

Toilet Paper Roll Holder shall be Model No 0705-Z as fabricated by American Specialties, Inc., 441 Saw Mill River Road, Yonkers, NY 10701-4913

**INSTALLATION**

Wall bracket is surface mounted using self tapping screws (supplied) through holes provided. Roll holder posts are mounted over top leg of brackets and secured by set screws from underside. For compliance with ADA Accessibility Guidelines install unit so that tissue roll centerline is between 44" (1118mm) maximum above finished floor (AFF) and 19" (483mm) minimum AFF.

Accessory Specialties

AMERICAN DISPENSER

Desert Ray Products

WATROUS INC.