



AMERICAN SPECIALTIES, INC.

441 Saw Mill River Road, Yonkers, NY 10701 (914) 476-9000

MODEL No: 0826

ISSUED: 1-87

REVISED: 6-98

SURFACE MOUNTED WASTE RECEPTACLE

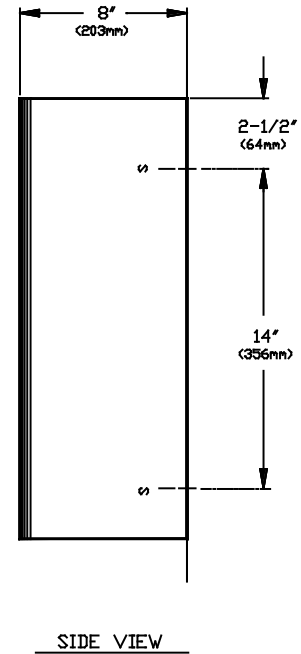
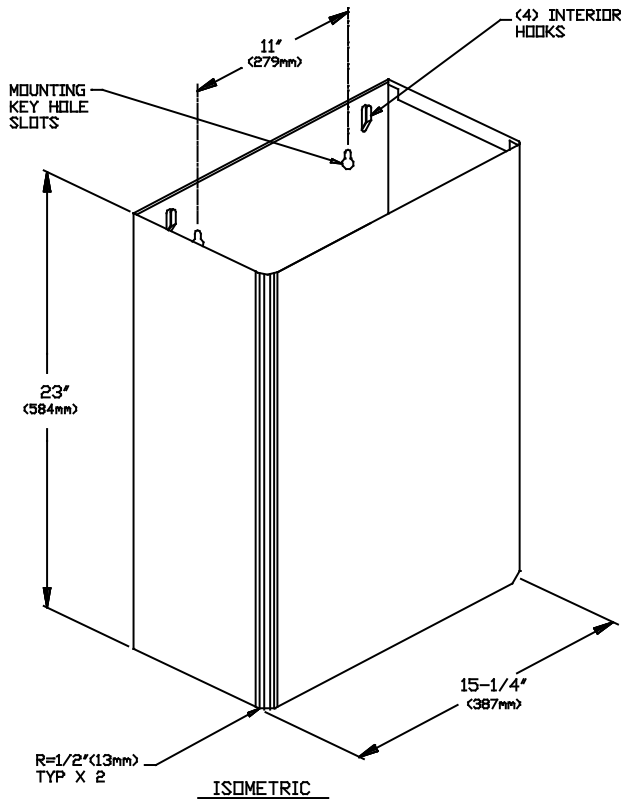

SPECIFICATION

Surface Mounted Waste Receptacle shall have a capacity of 12 gallons (45.4 liters). Unit shall be fabricated of alloy 18-8 stainless steel, type 304, N^o 22 gauge with N^o 4 satin finish and be protected during shipment with a PVC film easily removable after installation. Receptacle shall have no exposed fastening devices or spot welded seams and shall have front outer vertical edges rounded to 1/2" (13mm) radius. Receptacle shall have four (4) interior hooks for hanging a reusable heavy gauge clear vinyl bag with reinforced edges and grommets. Receptacle shall be mounted to wall through key hole slots on back of unit and be theft resistant after installation of concealed locking screw.

Surface Mounted Waste Receptacle shall be Model N^o 0826 as fabricated by American Specialties, Inc., 441 Saw Mill River Road, Yonkers, New York 10701-4913.

INSTALLATION

For general utility, mount the receptacle 39" (991mm) above finished floor (AFF) from top of unit. Hang unit on pre-installed four (4) screws (supplied) on wall through the mounting 'key hole' slots. Install and fasten theft-resistant screw (supplied) to wall through middle top hole of receptacle. For compliance with ADA Accessibility Guidelines, install unit so that top of receptacle is 54" (1372 mm) maximum AFF if clear floor side reach access is provided or 48" (1219mm) maximum AFF is clear floor forward reach access is provided.

OPERATION

User deposits waste material. Maintenance schedule determines trash removal cycle. Unit is emptied by removing collection liner bag to empty into appropriate bulk collection container. Liner is washable and reusable and replacements are available should they be required.

Accessory Specialties

AMERICAN DISPENSER

Desert Ray Products

WATROUS INC.