



AMERICAN SPECIALTIES, INC.

441 Saw Mill River Road, Yonkers, NY 10701 (914) 476-9000

MODEL No: 1002

ISSUED: 1-87

REVISED: 5-99

FREE-FLOW PAPER TOWEL DISPENSER

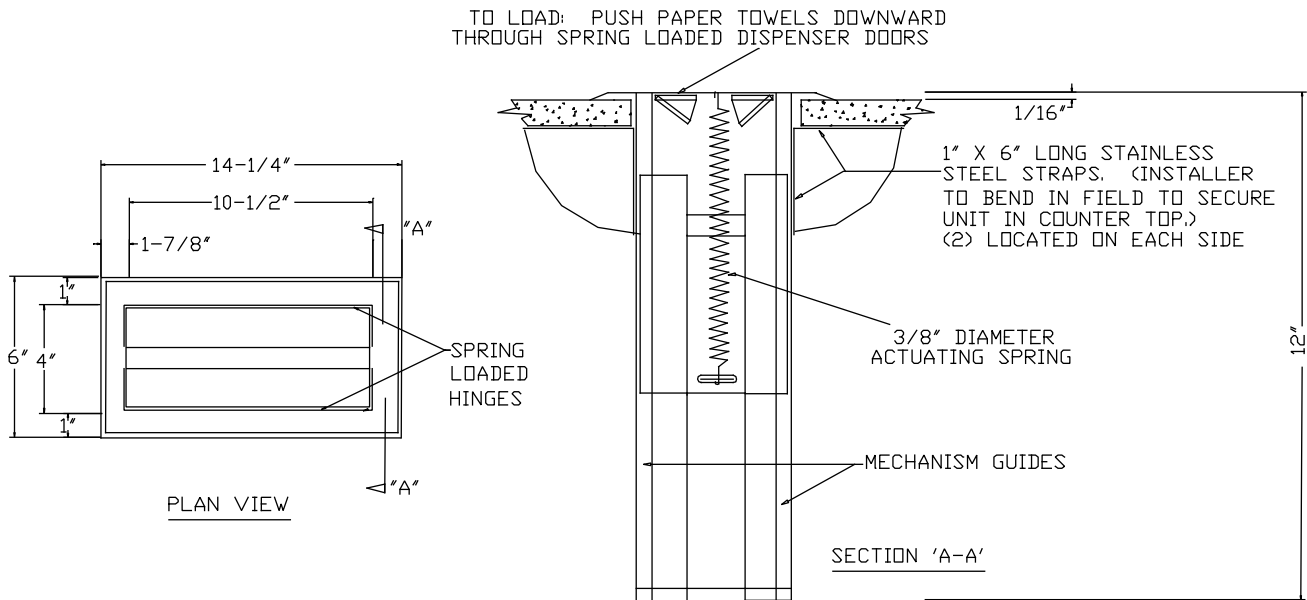

SPECIFICATION

Free-Flow Paper Towel Dispenser for counter-top mounting shall hold and dispense one (1) package of C-fold paper towels. Top frame and carrier grid frame shall be fabricated of alloy 18-8 stainless steel, type 304, №18 gauge. All exposed surfaces shall have №4 satin finish and be protected during shipment with a PVC film easily removable after installation. Face trim shall be one piece construction with no miters or welding. Flap doors shall have rolled edges and be mounted on heavy duty spring loaded hinges. Adjustable stainless steel mounting straps shall accommodate counter thicknesses from 1/2" to 4" (13mm to 102mm) thick. Spring actuated towel carrier mechanism shall be stainless steel №14 gauge and shall maintain constant dispensing pressure.

Free-Flow Paper Towel Dispenser shall be Model №1002 as fabricated by American Specialties, Inc., 441 Saw Mill River Road, Yonkers, New York 10701-4913.

INSTALLATION

Position unit into appropriate counter top cutout (by others). Installer to bend mounting straps upward to suit counter top thickness. Secure mounting straps to underside of counter top with mounting screws (supplied).

Counter Top Opening required is..... 4-1/4" x 12-1/2" (108mm x 318mm).

OPERATION

Paper towels are dispensed manually through flap doors until supply is depleted. A spring actuated towel carrier mechanism maintains towel dispensing pressure. Dispenser is refilled by pushing paper towels downward through flap doors. Supply is replenished on a cycle determined by maintenance needs.

Accessory Specialties

AMERICAN DISPENSER

Desert Ray Products

WATROUS INC.