



AMERICAN SPECIALTIES, INC.

441 Saw Mill River Road, Yonkers, NY 10701 (914) 476-9000

MODEL No: 8205

ISSUED: 1-87

REVISED: 7-99

L-SHAPED FOLD-UP PADDED SHOWER STALL SEAT (pg 1 of 2)

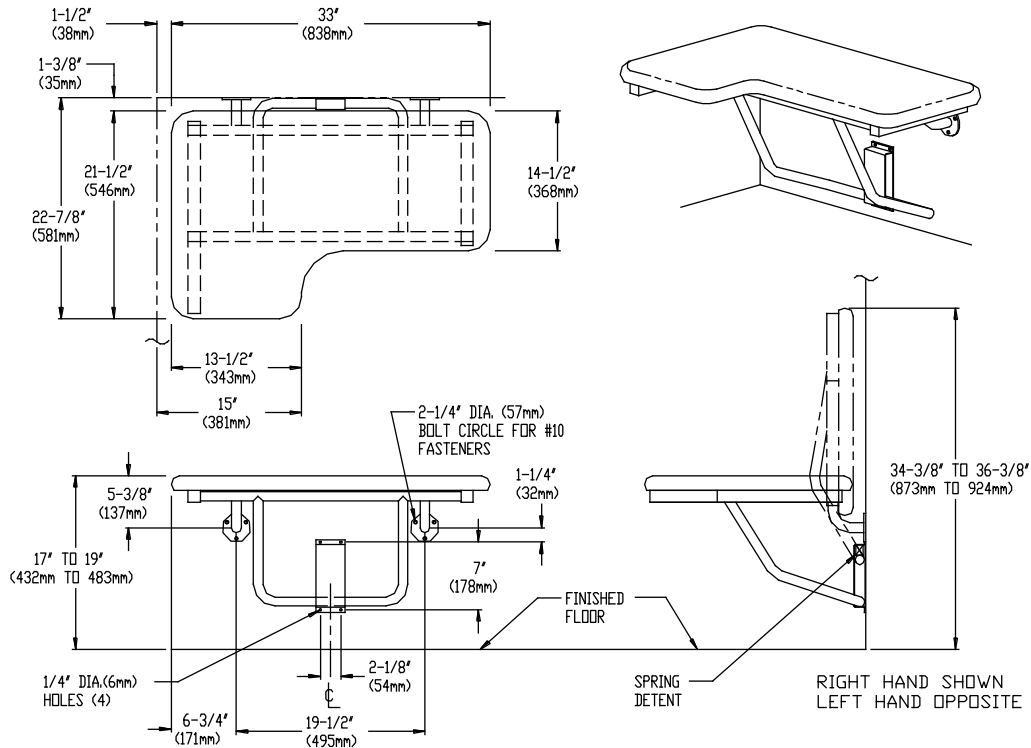

SPECIFICATION

"L-shaped" Fold-up Padded Shower Stall Seat shall have all metal parts fabricated of 18-8 stainless steel type 304; seat frame and support legs shall be 1" (25mm) dia. and 1-1/4" (32mm) square x 18 gauge (1.2mm) tubing with 3/16" (4.8mm) thick mounting flanges and 16 gauge (1.5mm) guide bracket/arm support. All exposed surfaces shall have N#4 satin finish. Structural assembly shall be of welded construction. All exposed edges and corners shall be radiused and/or deburred. Seat shall be sponge cushion covered with off-white Naugahyde® mounted on 1/2" (13mm) thick marine grade plywood. Support arm shall fold up when in retracted position to provide low profile against wall. No extra fittings shall be required to retain seat in storage position. Guide bracket shall control seat lowering into operating position. Unit shall satisfy ADA Accessibility Guidelines when mounted properly.

"L-Shaped" Fold-up Padded Shower Stall Seat shall be Model N^o 8205-____(L for left hand or R for right hand) as manufactured by American Specialties, Inc., 441 Saw Mill River Road, Yonkers, New York 10701- 4913

INSTALLATION

This unit is surface mounted. Installer/contractor must provide concealed anchor plate or blocking as specified in construction documents or as required by local building codes prior to wall finishing. Fasten unit flanges and guide bracket to concealed anchor or blocking plate with appropriate hardware. See "STRENGTH" section below. Note that concealed mounting plates or anchors and hardware are not supplied with this product and must be specified separately. Ensure that mounting configuration complies with local building codes.

STRENGTH

ASI Shower Seats are designed to meet and exceed ADAAG requirements as published in CABO/ANSI A117.1-1992 and CFR 28 Part 36, Federal Register Vol. 56, N^o 144, July 26, 1991, section 4.21.3 and section 4.26.3, that fabricated product shall be of adequate strength to support a load of 250 pounds (113.4 kg) and unit shall conform to size and edge clearances as diagrammed. Mounting to the wall is a critical part of the system to meet this requirement. To withstand the shear, tension or pull-out, and torsion loads generated by the maximum loading, the fastener system must be adequately sized.

Accessory Specialties

AMERICAN DISPENSER

Desert Ray Products

WATROUS INC.



AMERICAN SPECIALTIES, INC.

441 Saw Mill River Road, Yonkers, NY 10701 (914) 476-9000

MODEL No: 8205

ISSUED: 1-87

REVISED: 7-99

L-SHAPED FOLD-UP PADDED SHOWER STALL SEAT (pg 2 of 2)

MATERIALS

Tube: 18 gauge (.048 in. <1.22mm> thick), type 304 stainless steel 1" (25mm) dia. and 1-1/4" (32mm) square. Unitized all welded construction. Exposed surfaces have satin finish. Edges and corners are radiused and burr free.

Flange: 3/16" (4.8mm thick), type 304, stainless steel. Exposed surfaces have satin finish. Edges and corners are radiused and burr free.

Bracket: 16 gauge (.06 in. <1.52mm> thick), type 304, stainless steel. Exposed surfaces have satin finish. Edges and corners are radiused and burr free.

Seat: Closed cell medium density foam cushion covered with off-white Naugahyde® on a 1/2" (13mm) thick base of marine grade plywood. Seat cover top edge seam is sewn internally, laid flat and re-stitched for strength and smooth comfort. Bottom edge seam is tuck-and-roll construction. All seams are sewn using mildew-resistant Nylon® heavyweight thread. Bottom is fully covered and edges are tucked and concealed stainless steel stapled to base. Concealed mounting is from bottom with stainless steel screws into stainless steel inserts. Overall size 33"W x 21-1/2"D (838mm x 546mm).

Spring: Stainless steel wire, type 304, 1" body dia. (25 mm) x 3" body length (76mm) x .075" Dia. (1.91mm).

OPERATION

Fold-up Shower Seat requires only one hand operation to manually lower to horizontal position for use or raise for departure and arrival. Guide bracket with spring detent prevents seat from dropping and provides positive support in usage position as well as spring locked storage position.