



AMERICAN SPECIALTIES, INC.

441 Saw Mill River Road, Yonkers, NY 10701 (914) 476-9000

MODEL No: 9012

ISSUED: 1-99

REVISED: 9-99

HORIZONTAL BABY-CHANGING STATION (pg 1 of 2)

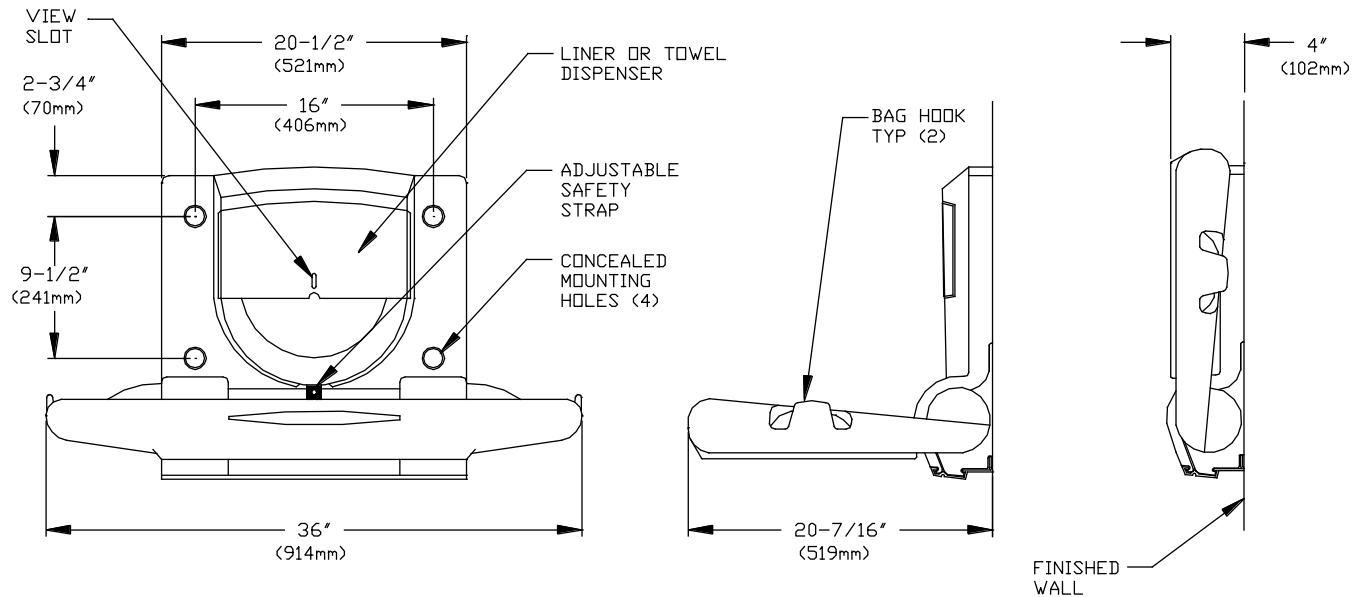

SPECIFICATION

Baby-Changing Station shall be horizontal format and shall protrude no more than 4" (102mm) from wall when in retracted position. Unit shall comply with Federal ADA Accessibility Guidelines, CALDAG & CABO/ANSI A117.1-1992. Unit shall have a maximum holding capacity of 250 lbs. (113.4 kg) and shall be fabricated of non-porous plastic (FDA approved HDPE) tested according to ASTM G21 and ASTM G22. No metal parts shall be visible when unit is open or closed and no parts of the operating mechanism shall be accessible when unit is open or closed to provide a tamper-resistant and pinch proof user environment. Unit shall have a damped gas spring to assist user in opening and closing unit with one hand. Unit shall be provided with two integral heavy-duty bag hooks clearly marked with international-style symbols. Unit shall provide a bed-liner dispenser with concealed, self-latching lock requiring no keys, that may be easily converted to a multi-fold towel dispenser with no adapters. A view slot shall be provided to indicate low liner/towel condition. Unit shall not prominently display any garish graphics or brand name on exterior surfaces. Unit shall provide graphic and instructions in seven languages on interior back wall and an identifying plaque for a washroom entryway shall be provided. Unit shall be provided with an adjustable two-part child protection safety-strap mounted with concealed fasteners on high walls of cradle. Rear strap shall be vinyl coated. Entire unit shall be assembled of completely sealed components to provide easy cleaning and no penetration zones to harbor microbes or bacteria. Unit shall provide no level surfaces when open or closed that may invite the resting or placement of cups, cans, bottles or cigarettes. Unit shall mount on standard stud wall dimensions and with proper anchoring may mount on all suitable wall constructions. Mounting fasteners shall be concealed after installation using color matched recess plug-covers supplied. Unit shall be a light grey color. Unit shall be recyclable at end of usable life to help reduce global waste. Unit shall be warranted for (5) years against defects in material or workmanship.

Horizontal Baby-Changing Station shall be Model N^o 9012 as manufactured by American Specialties, Inc., 441 Saw Mill River Road, Yonkers, New York 10701-4913

Accessory Specialties

AMERICAN DISPENSER

Desert Ray Products

WATROUS INC.



AMERICAN SPECIALTIES, INC.

441 Saw Mill River Road, Yonkers, NY 10701 (914) 476-9000

MODEL No: 9012

ISSUED: 1-99

REVISED: 9-99

HORIZONTAL BABY-CHANGING STATION (pg 2 of 2)

INSTALLATION

Unit is surface mounted using hardware supplied through recessed mounting holes provided. Hardware kit supplied has fasteners suitable for metal or wood stud walls and general hollow wall construction. Fasteners and anchors for masonry walls are not provided. Wall reinforcement must be suitable to sustain transfer of rated unit loading. Mounting hole plug covers are supplied to conceal fasteners after installation. A template and mounting/operation/maintenance instruction booklet is supplied with each unit.

To comply with ADA Accessibility Guidelines install unit with top of changing table 32" - 34" (813-864mm) above finished floor when in horizontal position.

1. Locate wall studs at 16" (406mm) o.c. for fastening the station. If wall studs cannot be used, drill pilot holes and install toggle fasteners securely in the wall. Follow dimensions on installation diagram included with unit.
2. Attach unit to wall studs with four (4) 1/4" x 3" long Philips panhead self-tapping screws with flat washers.
3. Where wall studs are not available, attach with four (4) 1/4" - 20 x 3" bolts with flat washers into toggles, or expansion nuts.

OPERATION

Unit platform is shaped to cradle a child's body. Unit is easily opened and closed by user with one hand anywhere on top or front edge of bed. Bed liner/towel dispenser presents liners or towels for user hygiene and convenience. Dispenser lip retains stack for single liner/towel dispensing. Safety strap is easily adjustable by user for baby size and Sure-Lok latch securely resists opening until released by opposing finger pressure by adult caretaker. Liners/towels are easily replenished by service personnel as required.