

160BN BluNose High Impact Corner Guard

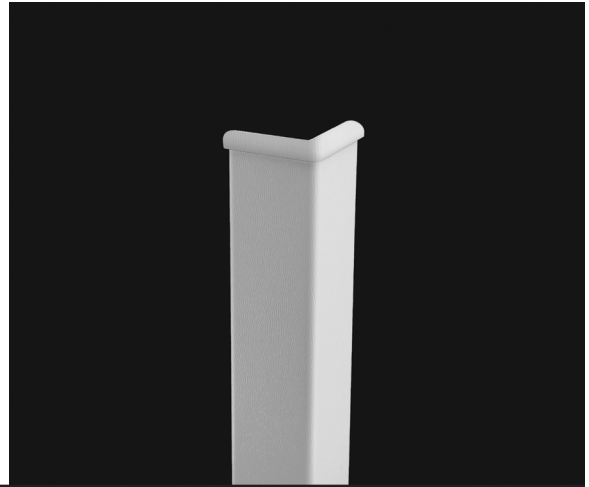

Product Guide

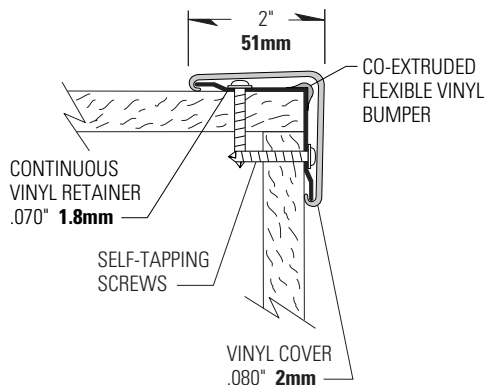
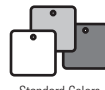

- ▶ 2" wing (51mm) with 90° corner protection
- ▶ Mounted on a .070" (1.8mm) thick continuous vinyl retainer with a co-extruded flexible vinyl apex
- ▶ Vinyl retainer is four times stronger than our aluminum retainer and six times stronger than any other vinyl retainer
- ▶ .080" (2mm) thick scratch and stain resistant rigid vinyl cover
- ▶ Manufactured 3' (.91m), 4' (1.22m), 8' (2.44m), 9' (2.74m) and 12' (3.66m) standard heights, custom heights available
- ▶ Quick ship applies to 4' (1.22m) and 8' (2.44m) heights only

IPC.382/REV.3

160BN BluNose High Impact Corner Guard Suggested Specifications

PART 1 - GENERAL

1.01 SUMMARY

A. Corner guard system for wall protection

1.02 SECTION INCLUDES

A. 160 BluNose High Impact Surface Mount Corner Guard System

1.03 REFERENCES

A. American Society for Testing and Materials (ASTM)

B. National Building Code of Canada (NBC)

C. National Fire Protection Association (NFPA)

D. Society of Automotive Engineers (SAE)

E. Underwriters Laboratory (UL)

F. Underwriters Laboratory of Canada (ULC)

G. Uniform Building Code (UBC)

1.04 SYSTEM DESCRIPTION

A. Performance Requirements: Provide corner guard system that conform to the following requirements of regulatory agencies and the quality control of IPC Door and Wall Protection Systems, InPro Corporation.

1. Fire Performance Characteristics: Provide UL Classified corner guards conforming with NFPA Class A fire rating. Surface burning characteristics, as determined by UL-723 (ASTM E-84), shall be flame spread of 10 and smoke development of 350 - 450.

Provide ULC (Canada) listed corner guards conforming to the requirements of the National Building Code of Canada 1990, Subsection 3.1.13. Surface burning characteristics, as determined by CAN/ULC-S102.2, shall be flame spread of 15 and smoke developed of 35.

2. Self Extinguishing: Provide corner guards with a CC1 classification, as tested in accordance with the procedures specified in ASTM D-635-74, Standard Test Method for Rate of Burning and/or Extent and Time of Burning of Self-Supporting Plastics in a Horizontal Position, as referenced in UBC 52-4-1988.

3. Impact Strength: Provide rigid vinyl profile materials that have an Impact Strength of 30.2 ft-lbs/inch of thickness as tested in accordance with the procedures specified in ASTM D-256-90b, Impact Resistance of Plastics.

4. System Impact Resistance: Provide a corner guard system that resists an impact of 153.9 ft-lbs while producing no visual blemishes upon the vinyl cover surface and no deformations in the vinyl retainers, as tested in accordance with the applicable provisions of ASTM F 476-84, paragraph 18, Impact Test.

5. Chemical and Stain Resistance: Provide corner guards that show resistance to stain when tested in accordance with applicable provisions of ASTM D-543.

6. Fungal and Bacterial Resistance: Provide rigid vinyl that does not support fungal or bacterial growth as tested in accordance with ASTM G-21 and ASTM G-22.

7. Color Consistency: Provide components matched in accordance with SAE J-1545 - (Delta E) with a color difference no greater than 1.0 units using CIE Lab, CIE CMC, CIE LCh, Hunter Lab or similar color space scale systems.

1.05 SUBMITTALS

A. Product Data: Manufacturer's printed product data for each type of corner guard specified.

B. Detail Drawings: Mounting details with the appropriate fasteners for specific project substrates.

C. Samples: Verification samples of corner guard, 8" (203mm) long, in full size profiles of each type and color indicated.

D. Manufacturer's Installation Instruction: Printed installation instructions for each corner guard.

1.06 DELIVERY, STORAGE AND HANDLING

A. Deliver materials in unopened factory packaging to the jobsite

B. Inspect materials at delivery to assure that specified products have been received.

C. Store in original packaging in a climate controlled location away from direct sunlight.

1.07 PROJECT CONDITIONS

A. Environmental Requirements: Products must be installed in an interior climate controlled environment.

1.08 WARRANTY

A. Standard IPC Limited Lifetime Warranty against material and manufacturing defects.

PART 2 - PRODUCTS

2.01 MANUFACTURER

A. Acceptable Manufacturer: IPC Door and Wall Protection Systems, InPro Corporation, PO Box 406 Muskego, WI 53150 USA; Telephone: 800-222-5556, Fax: 888-715-8407, Internet address: <http://www.inprocorp.com>

B. Substitutions: Not permitted

C. Provide all corner guards and wall protection from a single source.

2.02 MANUFACTURED UNITS

A. Corner Guard System

160BN BluNose High Impact Corner Guard Profile

2" (51mm) x 2" (51mm), 90 degree

3' (.91m), 4' (1.22m), 8' (2.44m) and 9' (2.74m) standard heights

Custom heights available

2.03 MATERIALS

A. Vinyl Covers: Snap on cover of .080" (2mm) thickness shall be extruded from chemical and stain resistant polyvinyl chloride with the addition of impact modifiers. No plasticizers shall be added (plasticizers may aid in bacterial growth).

B. Vinyl Retainers: Continuous vinyl retainers of .070" (1.8mm) thickness with a co-extruded flexible vinyl apex shall be fabricated from polyvinyl chloride with the addition of impact modifiers.

2.04 COMPONENTS

A. Top caps and bottom caps shall be made of injection molded thermoplastics.

B. Fasteners: All mounting system accessories appropriate for substrates indicated on the drawings shall be provided.

2.05 FINISHES

A. Vinyl Covers: Colors of the corner guard to be selected by the architect from the IPC finish selection. Surface shall have a pebble texture.

B. Molded Components: Top caps and bottom caps shall be of a color matching the corner guards. Surface shall have a pebble texture.

PART 3 - EXECUTION

3.01 EXAMINATION

A. Examine areas and conditions in which the corner guard systems will be installed.

1. Complete all finishing operations, including painting, before beginning installation of corner guard system materials.

B. Wall surface shall be dry and free from dirt, grease and loose paint.

3.02 PREPARATION

A. General: Prior to installation, clean substrate to remove dust, debris and loose particles.

3.03 INSTALLATION

A. General: Locate corner guard as indicated on the approved detail drawings for the appropriate substrate and in compliance with the IPC installation instructions. Install corner guard level and plumb at the height indicated on drawings.

B. Installation of 160BN BluNose High Impact Surface Mount Corner Guard:

1. Retainer Installation

Position the vinyl retainer against the wall, allowing 5/16" (8mm) from the bottom of the retainer to the top of the cove base or baseboard for the bottom cap.

Drywall: Secure the retainer to the wall using #8 x 1-1/4" phillips round head, self-tapping screws. Stagger the fasteners on each wing of the retainer. Use 4 screws per 3' (.91m) length, 6 screws per 4' (1.22m) length, 10 screws per 8' (2.44m) length, or 12 screws per 9' (2.74m) length.

Concrete: Drill 1/4" (6.5mm) holes into the ends of the retainer for the top and bottom caps. Stagger the holes on each wing of the cap. Use the slotted tabs on the top and bottom cap to transfer hole location to the retainer. Drill 1/4" (6.5mm) holes on the two wings of the retainer. Stagger the fasteners on each wing of the retainer. Drill 4 holes per 3' (.91m) length, 6 holes per 4' (1.22m) length, 10 holes per 8' (2.44m) length, or 12 holes per 9' (2.74m) length. Transfer the location of all mounting holes to the wall. Drill 1/4" (6.5mm) holes and position ALLIGATOR anchors into the holes on the wall. Mount the retainer with #10 x 1-3/4" phillips pan head screws and tighten to secure the retainer to the wall.

2. Top and Bottom Cap Installation:

Drywall: Overlap the retainer with the mounting tabs of the top and bottom caps and attach them to the retainer using two, #8 x 1-1/4" phillips flat head, self-tapping screws per cap. Stagger the fasteners on each wing of the cap.

Concrete: Overlap the retainer with the mounting tabs of the top and bottom caps and attach them to the retainer and into the ALLIGATOR anchors using two, #8 x 1-1/2" phillips flat head screws per cap.

3. Position the vinyl cover on the retainer to check the fit. Adjust the top cap on the retainer to obtain a tight fit with the vinyl cover. Starting at the top, push the vinyl cover over the retainer pressing over the entire length until the cover snaps securely into place.

INSTALLATION NOTE: Vinyl retainers can be field bent to angles 10' wider or 10' tighter than 90'. When doing so top and bottom caps cannot be used and the installation should be full height from floor to ceiling.

3.04 CLEANING

A. At completion of the installation, clean surfaces in accordance with the IPC clean-up and maintenance instructions.

P.O. Box 406 · Muskego, Wisconsin 53150 USA

www.inprocorp.com

Nationwide 800.222.5556/Fax 888.715.8407

International Sales 262.679.5521 / Fax 262.679.5524